



Ion Source High Voltage Cabinet Expression of Interest Overview

UT-Battelle (the Company) seeks an Expression of Interest (EOI) for multiple Ion Source High Voltage Cabinets. These Cabinets will be delivered to Oak Ridge National Laboratory (ORNL) in support of a DOE funded research and development program. The scope of work includes refinements of final design for manufacturing, procurement of commercially available components, fabrication, assembly, inspections, testing, storage (as needed) and delivery.

The Ion Source High Voltage Cabinet Request for Proposal (RFP) is expected to be issued in October 2023 for the first two (2) cabinets with work to begin immediately after contract award. Required delivery schedule will be finalized at time of purchase order award, however the current estimated delivery is August 2024. The award will be a single, competitive fixed price contract and may include options for up to an additional twenty (20) cabinets to be fabricated and delivered in multiple subsequent orders with possible deliveries in late 2024, 2025, & early 2026. The optional units could be purchased in multiple orders with varying schedules & quantities. There is no guarantee of additional orders beyond the original scope.

Disclaimer: This EOI neither constitutes a solicitation, Request for Proposal (RFP), Invitation for Bid, or promise to issue an RFP, nor does it restrict UT-Battelle to a specific acquisition approach.

SCOPE – The scope includes refinement of final design for manufacturing, procurement of commercially available components, fabrication, assembly, inspections, testing, storage (as needed) and delivery of the Ion Source High Voltage Cabinet according to Company provided design drawings, assembly drawings, solid models, Specifications, and Statements of Work.

The Ion Source High Voltage Cabinet consists of two independent cabinets that will be integrated into a single enclosure. These two cabinets will be modular with independent structures but must be designed together to ensure mechanical and electrical integrity of the system. The two main cabinets will be defined as the “Ion Source Cabinet” and the “High Voltage Platform”. The cabinets consist of a custom stainless frame and sheet metal fabrication that encloses AC power distribution, control electronic, pneumatic, chilled water equipment, and toxic/hazardous gas handling equipment at both ground potential and installed on a high voltage equipment platform. The high voltage platform is biased up at 50 kVDC from ground and includes 208 VAC 3-phase electrical distribution system provided through isolation transformers. Bolted on and removable, the Annex enclosure attaches to the Ion Source Cabinet and is designed to install around a separate component external to the scope of this solicitation.

The Ion Source Cabinet contains power supply racks, breaker panels and equipment bays at ion source ground potential. The Ion Source Cabinet also contains a High Voltage Platform enclosure which contains power supplies, breaker panels, communications modules, an exhausted toxic gas panel, etc. at high voltage potential. The high voltage platform is electrically isolated from the rest of the structure by up to 60 kVDC. A set of 480V to 120VAC 60kVDC isolation stepdown transformers supply 208VAC 3Ph power to the high voltage platform.

Fabrication shall include support frames, decking, access panels, and any commercially procured equipment and/or components. All equipment provided by the Seller shall conform to applicable Occupational, Safety, and Health and National Electrical Code (NEC) regulation which are in force at the time the contract is signed. Equipment must have a National Recognized Testing Laboratory (NRTL) certification to U.S. standards. There are some components specified that may require Field Evaluations if vendors do not properly certify/mark. All panels, internal wiring, including field wiring, components and labeling shall conform to UL508A Edition 3 standards and each panel accordingly marked with NRTL certification. Any wiring/connections that fall outside of UL508A umbrella shall conform and be tested to IPC/WHMA-A-620 and NEC standards.

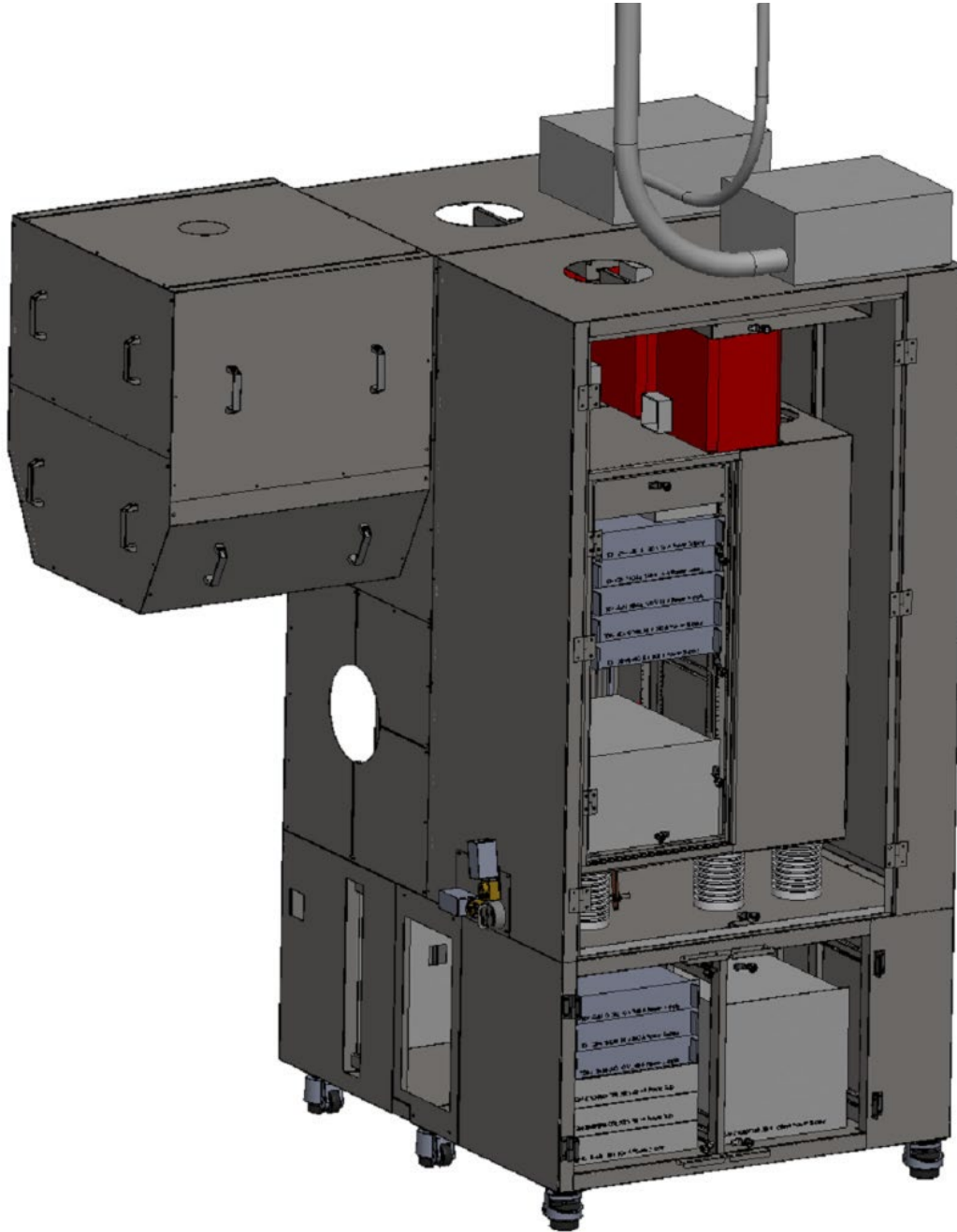

Approximate dimensions are as follows (length x width x height):

- Ion Source Cabinet
66" x 55" x 120"
- High Voltage Platform
49" x 39" x 50"
- Annex
38" x 37" x 42"

The design of the cabinet is basically complete and does not require extensive Seller design activities other than any fabrication specific "shop" type drawings. The complete design drawing package, Technical Specification, Statement of Work and Bill of Material will be provided as part of the RFP. Solid Models will also be provided to the successful bidder. Standard safety, documentation, and quality assurance requirements will be outlined within the Specification and Statement of Work package.

Successful bidders will be able to demonstrate experience in the following key areas:

- Fabrication experience of electrical cabinet enclosures with high voltage platforms with 50 kVDC or greater isolation transformers
- Mechanical installation within cabinet enclosures (air cooled chillers, compressed hazard gas handling systems, ventilation systems, pneumatics, hydronics, and exhaust systems)
- Fabrication experience of welded stainless steel structural electrical panels, support frame and enclosures in accordance to AWS D1.6/D1.6M - 2017 or later (Structural Welding Code – Stainless Steel)
- Fabrication experience of stainless-steel tubing (1/8" – 1/2") in accordance to ASME B31.3 - 2020 or later (Process Piping)
- Applicable certifications for stainless steel tubing, frame, and support structures, with testing and inspection certifications
- UL508A Certification along with fabrication experience of NRTL-listed systems with 480V-3ph, 208-3ph, 120V and 24VDC control systems
- Experience handling Export Controlled Information as defined by US-DOE and US-Department of Commerce. Note the designs and equipment are not subject to International Traffic in Arms regulations (ITAR), but similar information controls are required.

SUBMITTAL REQUIREMENTS – The EOI submittal requirements consist of a narrative summary overview up to a maximum of four (4) pages and shall, at a minimum, address the following:

- Company name, key contact, address, email and any other contact information.
- Main and Branch fabrication shop locations detailing capabilities of shops & personnel, including known sub-suppliers.
- Storage & throughput capabilities.
- Expected Proposal Development Duration.
- DOE/Federal Work Experience identifying relevant experience and any registration with DOE/Federal acquisition system(s).
- Provide summary of a minimum of three (3) projects of similar size and application.